



HIL Filter Housing

- industrial liquid

- Industrial single element liquid housing
- 1" BSPP or NPT inlet / outlet standard connections
- Suitable replacement for plastic housings
- Suitable for cartridge types DOE or 222



Specification

Materials of Construction

- Housing: 316L Stainless Steel
- Seals: EPDM FDA

Surface Finish

- Internal: As Welded
- External: Polished 0.8 µm Ra

All finishes pickled & passivated.

Welding

All assembly welds are full penetration. All welds are crevice and undercut free.

Weld finish & detail drawings available upon request.

Certification

Supplied as standard with vessel inspection certificate.

Material Test Certification

EN10204 3.1 supplied upon request.

Design Code

Housings designed in accordance with the European Council Pressure Equipment Directive (PED) 97/23/EC and the UK statutory Pressure Equipment Regulations (PER) 1999 N° 2001.

PED / PER conformity assessments based on Fluid Group 2 Gas (harmless) including steam. Only housings over PS.V 50 bar / litres bear the CE mark.

Design Basis

ASME VIII Division 1.

Working Condition PED 97/23/EC			Maximum Pressure		
Fluid Group	State	Temperature	011	012	013
Non Dangerous	Liquid / Gas	150 °C (302 °F)	10.00 barg (145.03 psig)	10.00 barg (145.03 psig)	10.00 barg (145.03 psig)
Dangerous	Liquid / Gas	150 °C (302 °F)	5.00 barg (72.51 psig)	5.00 barg (72.51 psig)	5.00 barg (72.51 psig)
PED Conformity Assessment Category			SEP	CAT I	CAT I
Volume (litres)			3.2	5.1	7.0

Physical Characteristics

Bowl Height	Dimensions (mm)			Weight (Kg)		
	'A'	'B'	'C'	Bowl	Head	Total
10" (250 mm)	150	441	297	1.5	1.2	3.8
20" (500 mm)	150	691	550	2.5	1.2	4.9
30" (750 mm)	150	936	814	3.5	1.2	6.0

Dimensions are based on illustration shown (HILCE011BB-B-E).
For accurate dimensions, please contact Parker dominick hunter.

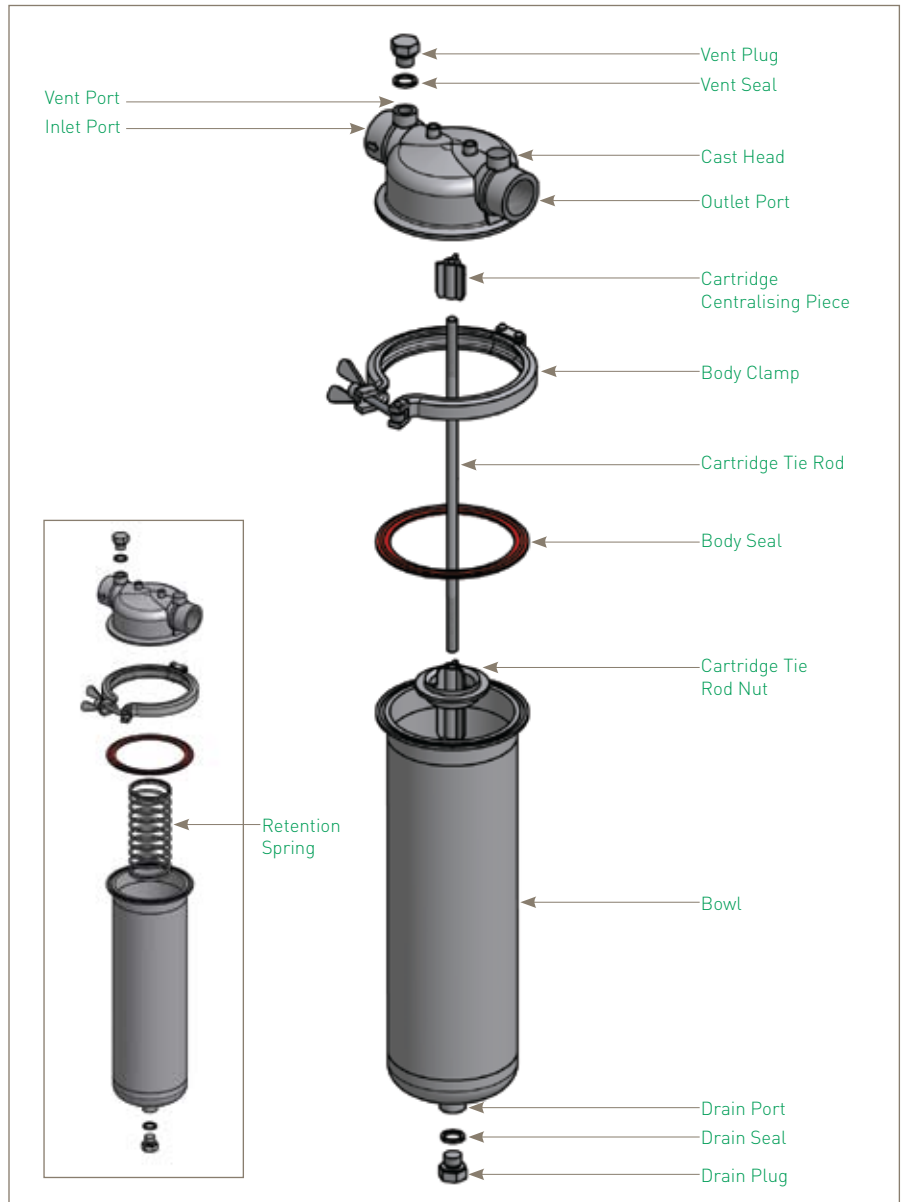
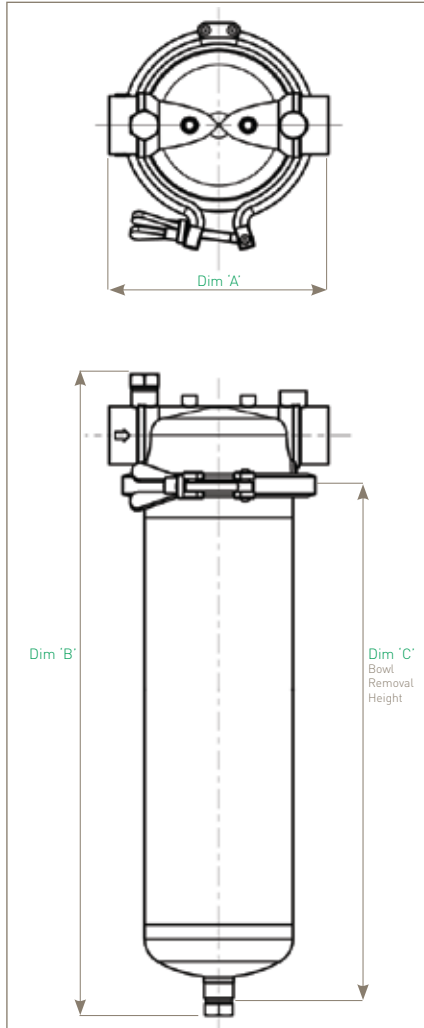

Ordering Information

HIL		01				-		-	
Code Vessel Class	Code Length (Nominal)	Code Connection Size	Code Standard	Code Cartridge	Code Seal				
CE Standard	1 10" (250 mm) 2 20" (500 mm) 3 30" (750 mm)	B 1" [25.4 mm]	B BSPP N NPT	B DOE D 222	E EPDM				

Note: For accessories, i.e. gauges, please contact Parker dominick hunter - Process Division for full availability.

For additional features, Parker dominick hunter offer this housing as part of its Standard PLUS Range.
Please see HIL® datasheet for more information.

Parker dominick hunter has a continuous policy of product development and although the Company reserves the right to change specifications, it attempts to keep customers informed of any alterations. This publication is for general information only and customers are requested to contact our Process Filtration Sales Department for detailed information and advice on a products suitability for specific applications. All products are sold subject to the company's Standard conditions of sale.

PROSEP FILTER SYSTEMS LTD
Unit G19
River Bank Way
Lowfields Business Park
Elland
West Yorkshire
HX5 9DN

Tel: 01422 377367

Fax: 01422 377369

Email: enquiries@prosep.co.uk

www.prosep.co.uk

Map and Directions to Prosep Filters Limited



Leave M62 at Junction 24.

At roundabout adjacent to Cedar Court Hotel take 2nd exit onto dual carriageway (A629), signposted Halifax.

Take 1st exit slip road.

At roundabout at end of sliproad, take 3rd exit off.

This is the entrance to Lowfields Business Park.

Proceed straight over 1st roundabout.

At next roundabout take 2nd exit onto River Bank Way - Prosep Filters can be found on the left after the S-bend.

[Link to Google Maps](#)