

NO.	PART NAME	MATERIAL
1	BODY	DUCTILE IRON SA 395
2	COVER	DUCTILE IRON SA 395
3	ELEMENT	STAINLESS STEEL
4	BACKWASH ARM	DUCTILE IRON
5	GASKET	BUNA-N
6	VENT VALVE 1/4" BSPT	STAINLESS STEEL
7	COTTER PIN	302 STAINLESS STEEL
8	DRIVE PIN	304 STAINLESS STEEL
9	ELASTIC STOP NUT	316 STAINLESS STEEL
10	GEAR REDUCER	CAST IRON
11	MOTOR - 1/4 HP	UNIT SUPPLIED W/O MOTOR
12	QUAD SEAL	BUNA
13	BACKWASH SHAFT	316 STAINLESS STEEL
14	O-RING	BUNA-N
15	STUD	STEEL SA 193 GR B7
16	HEX NUT	STEEL SA 194 GR 2H
17	PILOT BUSHING HOUSING	DUCTILE IRON SA 395
18	O-RING	BUNA-N
19	PILOT BUSHING	DELRIN
20	BACKWASH ARM GUIDE	DUCTILE IRON
21	WASHER	STEEL

NOTES:

1. ALL FLANGE CONNECTIONS CONFORM TO BS4504 PN16.
2. FOR REPLACEMENT PARTS, MODEL NO., SIZE, AND SERIAL NO., FROM THE STRAINER NAMEPLATE MUST BE FURNISHED.
3. MAX. WORKING PRESSURE: 150 PSI @ 150° F (10.3 BAR @ 65.5° C)
4. WEIGHT: DRY-1880 LBS. (855 KGS.)
WET-2675 LBS. (1216 KGS.)
COVER WEIGHT: 705 (320 KGS.)
5. PART NO.: 25961200701
6. EXTERNAL COATING: ENG'G SPEC. ES-301

SECTION "A-A"

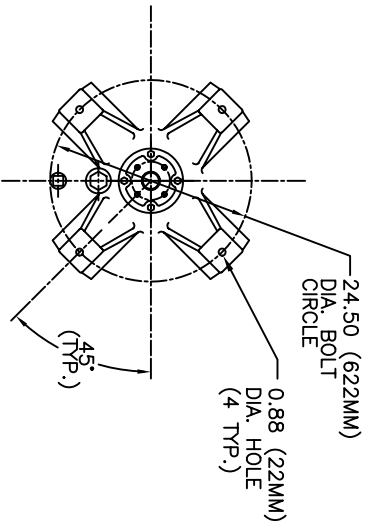

VIEW "B-B"
MOUNTING ARRANGEMENT

CERTIFIED FOR:
P.O. NO.:
S.O. NO.:
NO. OF UNITS:
TAG NOS.:

STRAINING ELEMENT:

ELECTRONIC FILE NAME: SD259632.DWG
REF. ECR D507
DATE 11/1/05

UNAUTHORIZED USE, MANUFACTURE OR REPRODUCTION IN WHOLE OR IN PART IS PROHIBITED. DRAWING, DESIGN AND OTHER DISCLOSURES PROPERTY OF EATON FILTRATION, LLC

		EATON FILTRATION, LLC 900 FAIRMOUNT AVENUE, ELIZABETH, NEW JERSEY 07207	
		NAME SIZE 300 MM (12") MODEL 2596 SELF-CLEANING STRAINER - DUCTILE IRON BS4504 PN16 FF FLANGES	DATE 5/23/97
DRAWN VAA	SIZE A	DWG NO	REV C
SD259632			

PROSEP FILTER SYSTEMS LTD
Unit G19
River Bank Way
Lowfields Business Park
Elland
West Yorkshire
HX5 9DN

Tel: 01422 377367

Fax: 01422 377369

Email: enquiries@prosep.co.uk

www.prosep.co.uk

Map and Directions to Prosep Filters Limited



Leave M62 at Junction 24.

At roundabout adjacent to Cedar Court Hotel take 2nd exit onto dual carriageway (A629), signposted Halifax.

Take 1st exit slip road.

At roundabout at end of sliproad, take 3rd exit off.

This is the entrance to Lowfields Business Park.

Proceed straight over 1st roundabout.

At next roundabout take 2nd exit onto River Bank Way - Prosep Filters can be found on the left after the S-bend.

[Link to Google Maps](#)